

Dual Dynamic Monitor Arms on 400 Post

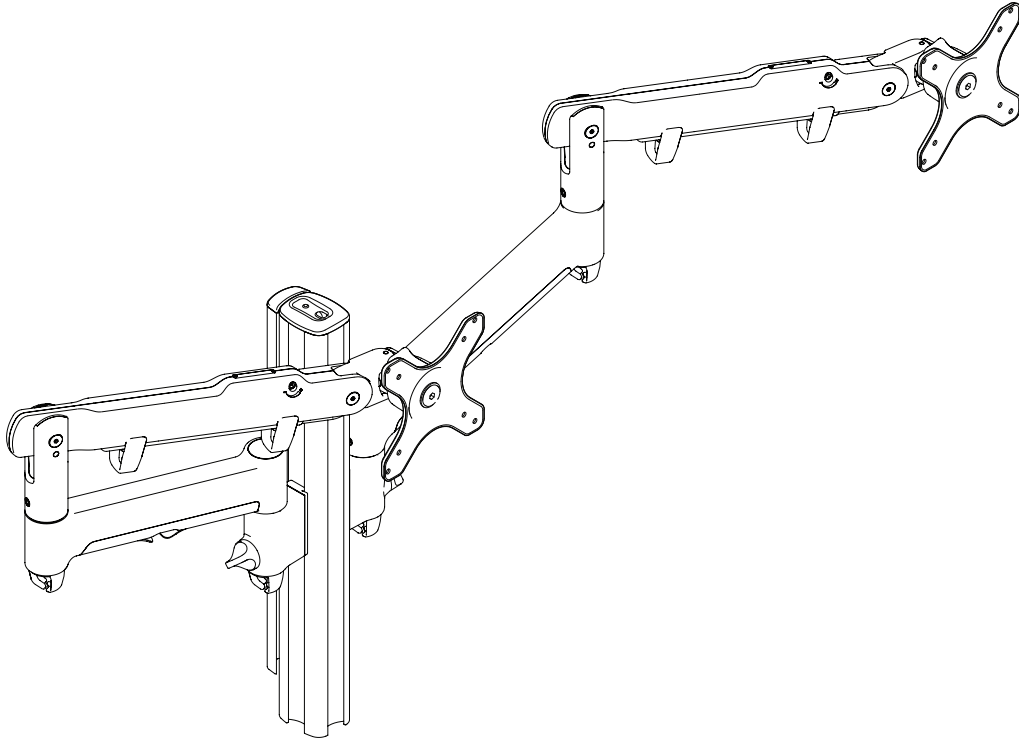

FEATURES

- Supports two monitors up to 24". Larger monitors may be compatible, refer to Monitor Size (page 2).
- Larger screens compatible when upgraded with sliders. Refer to AWM-HS Technical Specification for details.
- Adjustable counterbalance to suit a wide range of monitors.
- Tension gauge to make installation of multiple arms faster.
- Integrated 180° rotation limiter to prevent interference with desk mounted panels and dividers.
- Generous cable management guides cables discreetly down the arm to the work surface.

Monitor weight range	0-9kg (0 - 20lb)*
Vertical adjustment	633mm (30.12")
Tilt angle	+45 /- 25°
Monitor rotation	360°
VESA mounting	75x75 100x100

*Monitor weight should be within the weight range of all modular elements that make up the complete monitor mounting solution.

*Curved monitors, deep devices (such as all-in-one PCs) and offset VESA locations exert additional leverage that can exceed the capacity of the mount even though the monitor weight may be within the stated range. Please contact Atdec if you would like further information.

WARRANTY

10 years limited

MONITOR SIZES

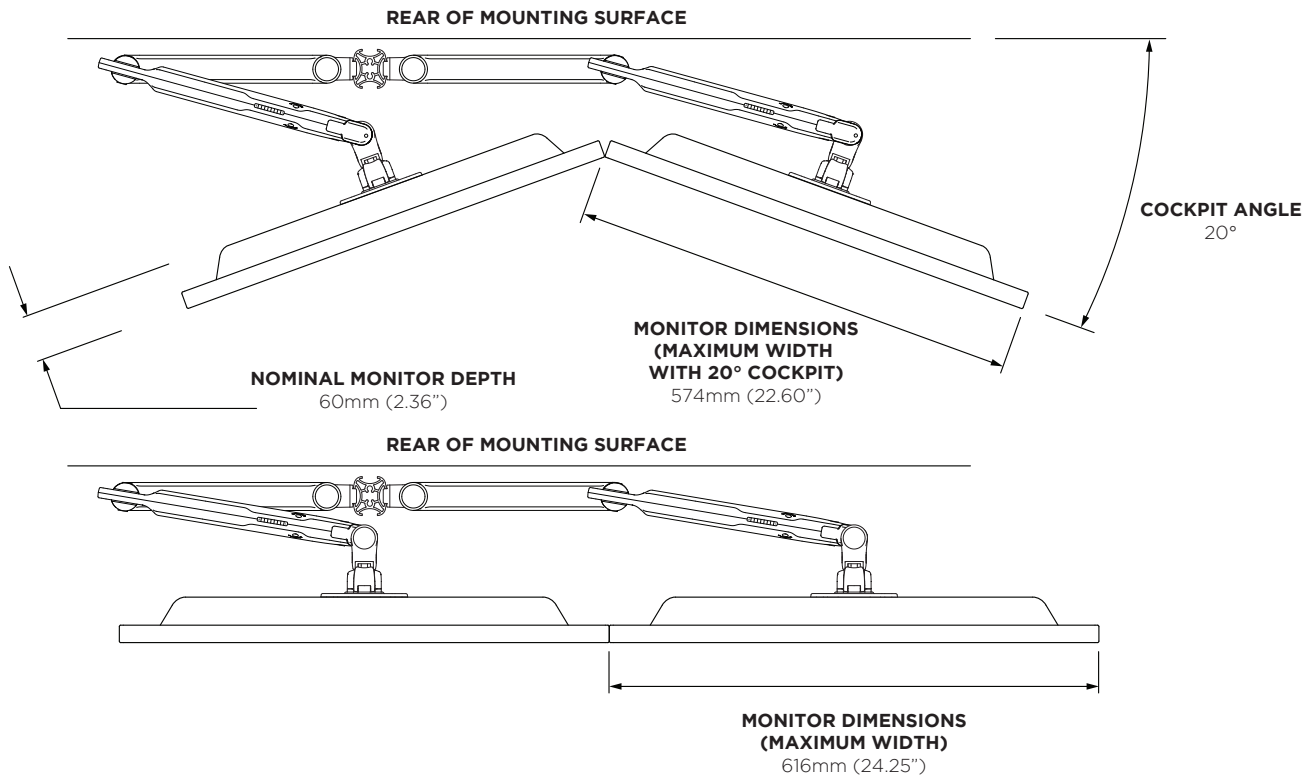

MOVEMENT - DYNAMIC ARM

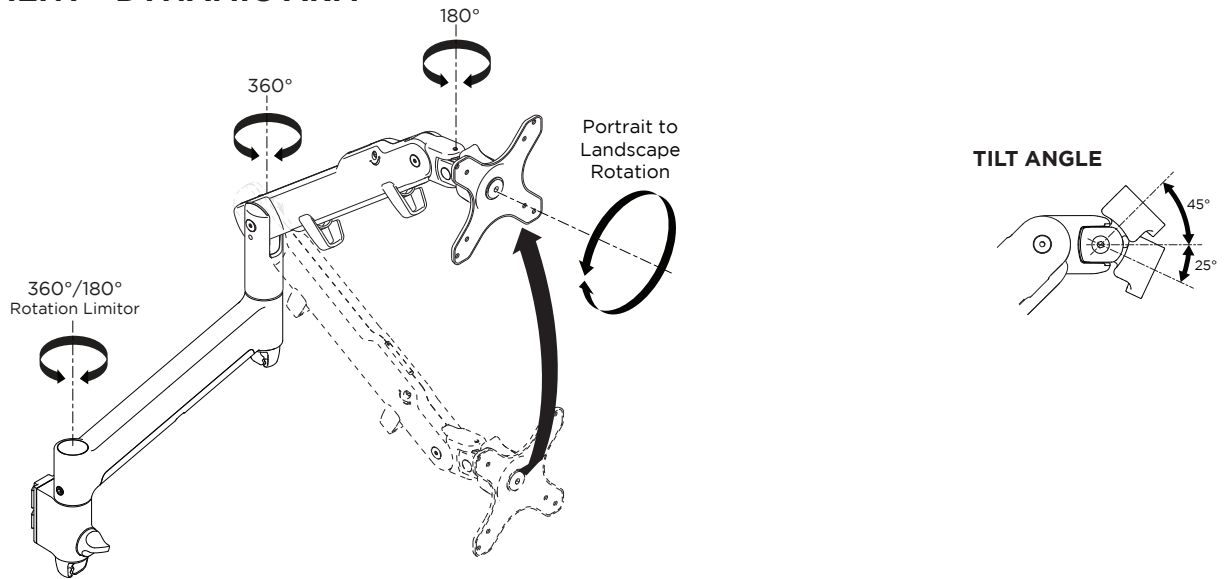

DIMENSIONS - DYNAMIC ARM ON 400 POST

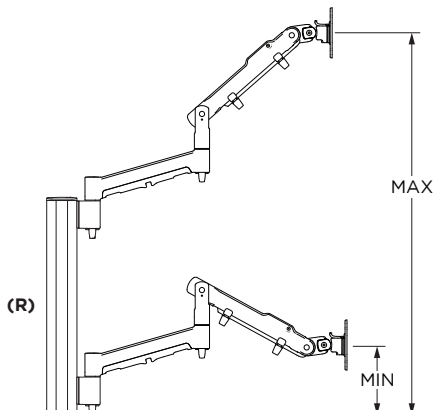

HEIGHT ON 400 POST *C CLAMP INCREASES MINIMUM HEIGHT ON POST BY 26MM (1")	MIN	MAX	RANGE (R)
	132mm* (5.20")	765mm* (30.12")	633mm* (24.92")

DIMENSIONS - DYNAMIC ARM ON POST

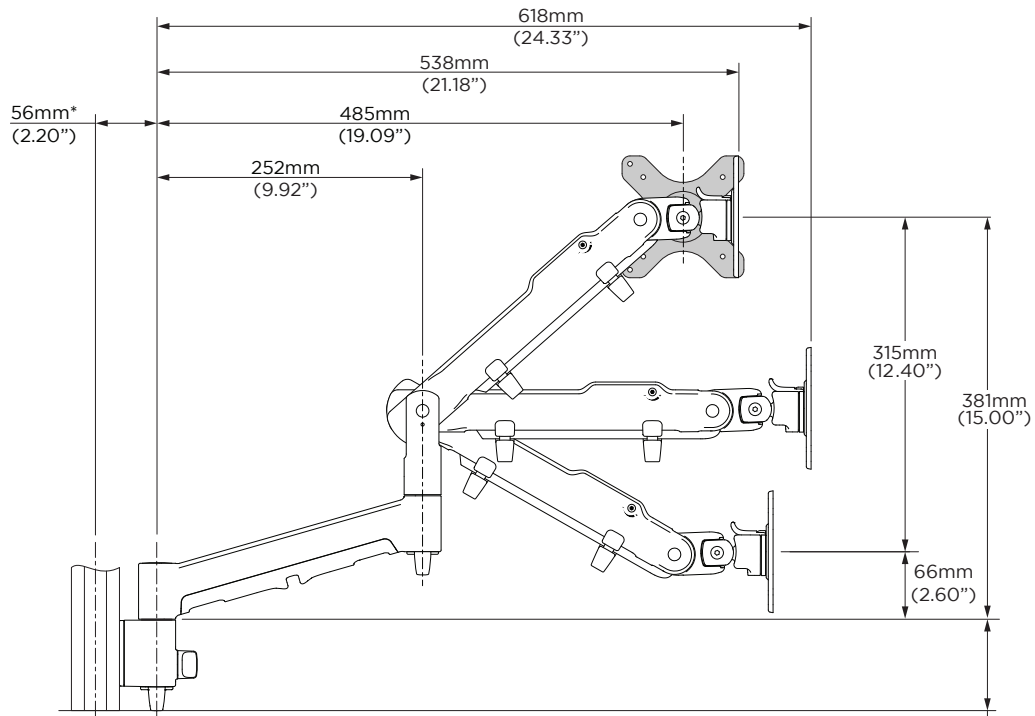

*Arm channel clamp shown mounted on side of post.

HEIGHT ON 400 POST	MIN	MAX
C Clamp increases minimum height on post by 26mm (1")	82mm (3.23")	400mm (15.75")

DIMENSIONS - DYNAMIC ARM ON POST POST SIDE ATTACHMENT

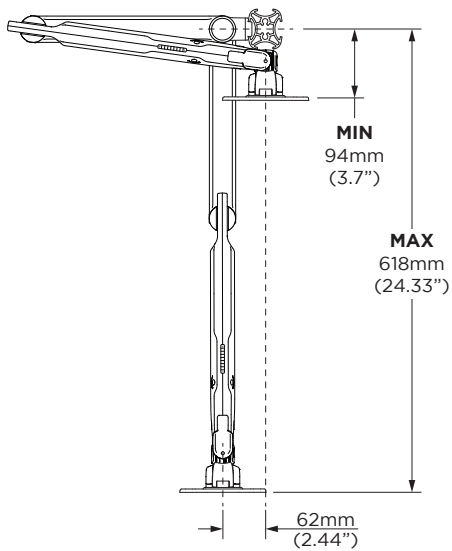

POST FRONT ATTACHMENT

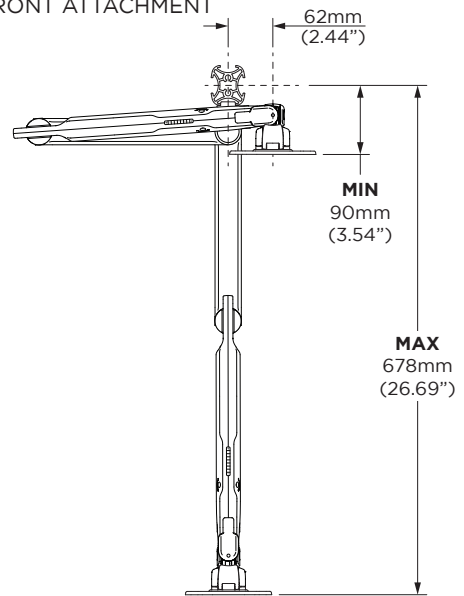

DIMENSIONS - VESA HEAD

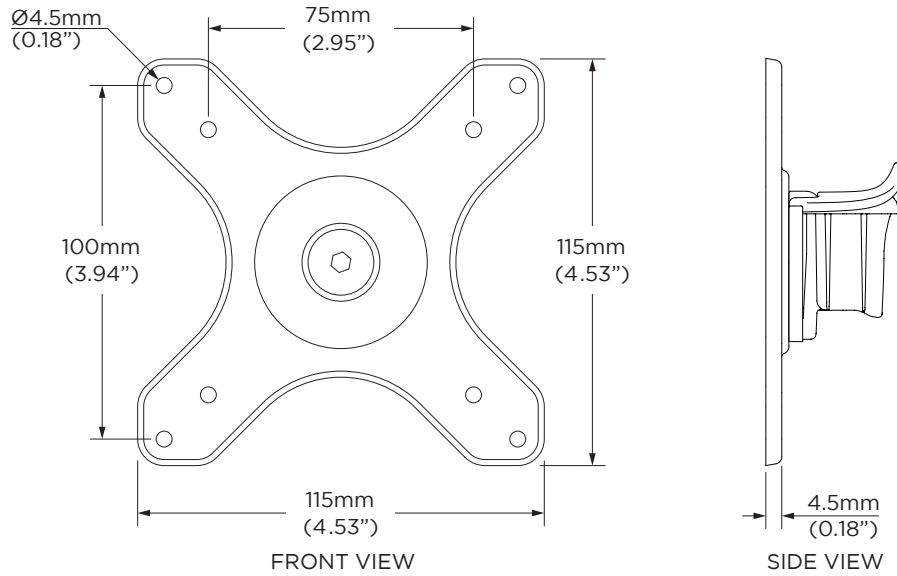

DESK FIXING OPTIONS

Below are the fixing options available for this solution. For more information and detailed specifications for these products please see the separate Technical Specifications available on the Atdec website.
 Note: Chosen desk fixing must be added to this solution code when ordering.

BOLT THROUGH AWM-FB

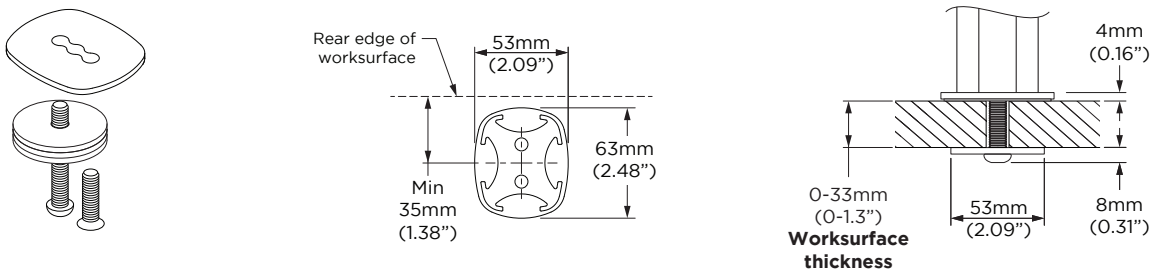

C CLAMP AWM-FC

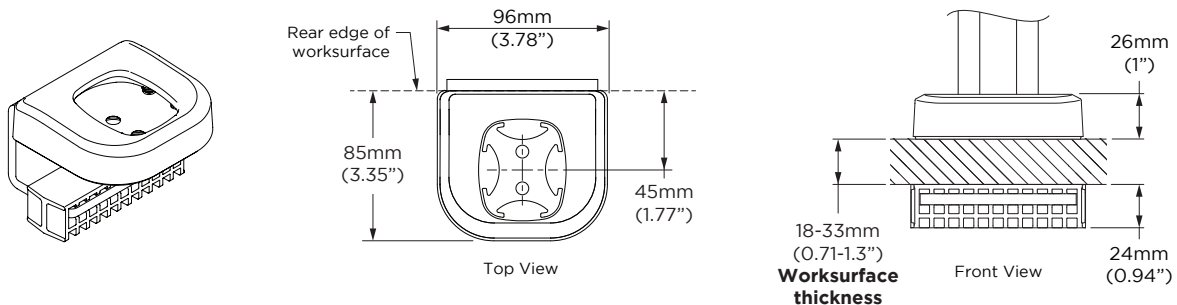

F CLAMP AWM-FF

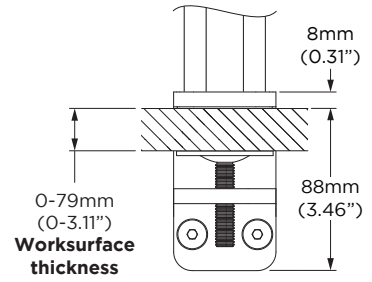
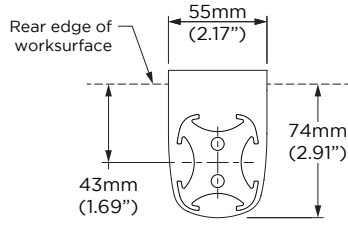
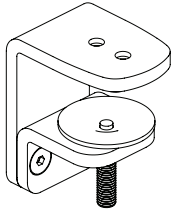

HEAVY DUTY F CLAMP AWM-FH

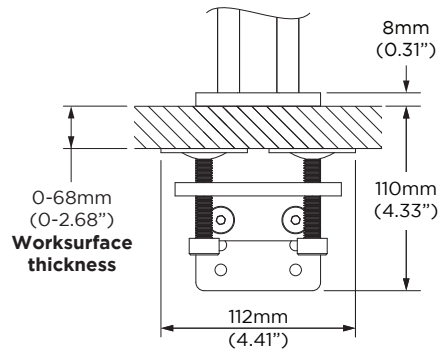
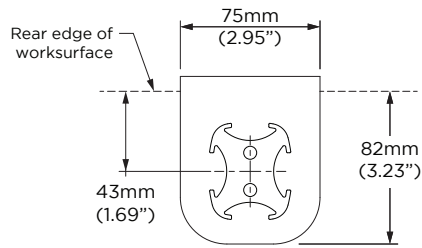
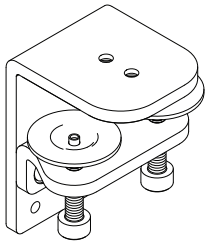

GROMMET CLAMP AC-GC

